

BEFORE YOU BEGIN

- All information is based on the latest product information available at the time of publication. Kohler China Ltd. reserves the right to make changes in product characteristics, packaging, or availability at any time without notice.
- These instructions contain important care, cleaning, and warranty information-**please leave these instructions for the consumer.**
- Make sure that the bath and the finished wall material are completely and correctly installed prior to installing your shower door. Prepare waterproof layer to wall and floor of the showering area. It is not allowed for any presence of electric switches and sockets. Make sure the floor drain runs smoothly.
- Before starting the door installation, lay out and identify all the parts. Use the exploded view illustrated on page 2 for reference.
- For the installation method of customized shower with different dimensions, please refer to this instructions.
- The product complies with QB 2584-2007.

⚠ CAUTION: Risk of injury or product damage.
 Tempered glass cannot be cut, drilled or knocked by hard object. Make sure corner area of the glass refraining from knocking so as to cause personal injury due to broken glass.

ATTENTION: Please install this door on Kohler receptors or curbs(Not included). If the curb is not Kohler-branded, please note its top width should be more than 80mm.

IMPORTANT: The shower door requires a flat vertical finished wall. The squareness of the wall is recommended no more than 3 mm/m. KOHLER Company won't take responsibility of the installation quality.

Do not use the enclosure for at least 24 hours.
 安装后 24 小时内请勿使用淋浴房。



安装之前

- 说明书中所有的资料是按最新出版的产品资料编写而成。科勒中国有限公司保留任何时候无须通知即可改变产品特性、包装或产品可供类型的权利。
- 说明书包括重要的安装、清洁及保养方面的内容, 请把这些资料交给用户阅读, 保管。
- 确保在安装淋浴房之前已经完整正确地安装了浴室和完工墙面材料。淋浴区墙地面应做防水处理, 并不得布置有电器开关、插座。确保地面排水通畅。
- 在进行淋浴房安装之前, 请拿出、排列并确认所有的零部件。请参考第 2 页上所示的分解图。
- 对尺寸与本标准产品不同的定制淋浴房, 参照本说明书进行安装。
- 本产品符合 QB 2584-2007。

⚠ 警告: 可能有人伤害或者产品损坏的危险。
 钢化玻璃不能进行切割, 钻孔或硬物敲击。搬移或安装过程中, 小心确保玻璃边、角部位不受撞击, 以防爆裂伤人。

建议: 将本产品安装在科勒淋浴盆或挡水条上(需另行购买)。如自备挡水条, 建议顶面宽度尺寸大于 80mm。

重要事项: 淋浴房需要安装在平坦垂直的墙面上。墙面的垂直度推荐在正负 3mm/m 以内。如果超出此范围, 科勒公司将不保证淋浴房的完美使用。

ROUGHING-IN

尺寸图

Unit: mm
 单位: 毫米

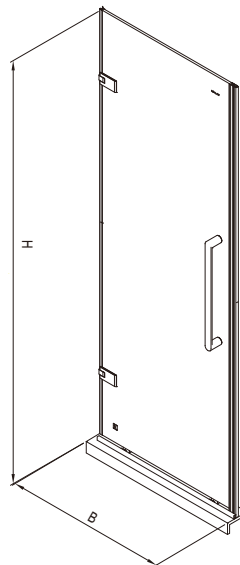

ALEO	SKU	B	H
	K-704643T		
	K-704651T		

ZHONGSHAN KOHLER SHOWER CO., LTD. NO13-1, XINGYE ROAD, ZHONGSHAN TORCH DEVELOPMENT ZONE, ZHONGSHAN, GUANGDONG, CHINA POST CODE: 528437
 中山科勒卫浴有限公司 广东省中山市中山火炬开发区兴业路 13-1 号 邮编: 528437

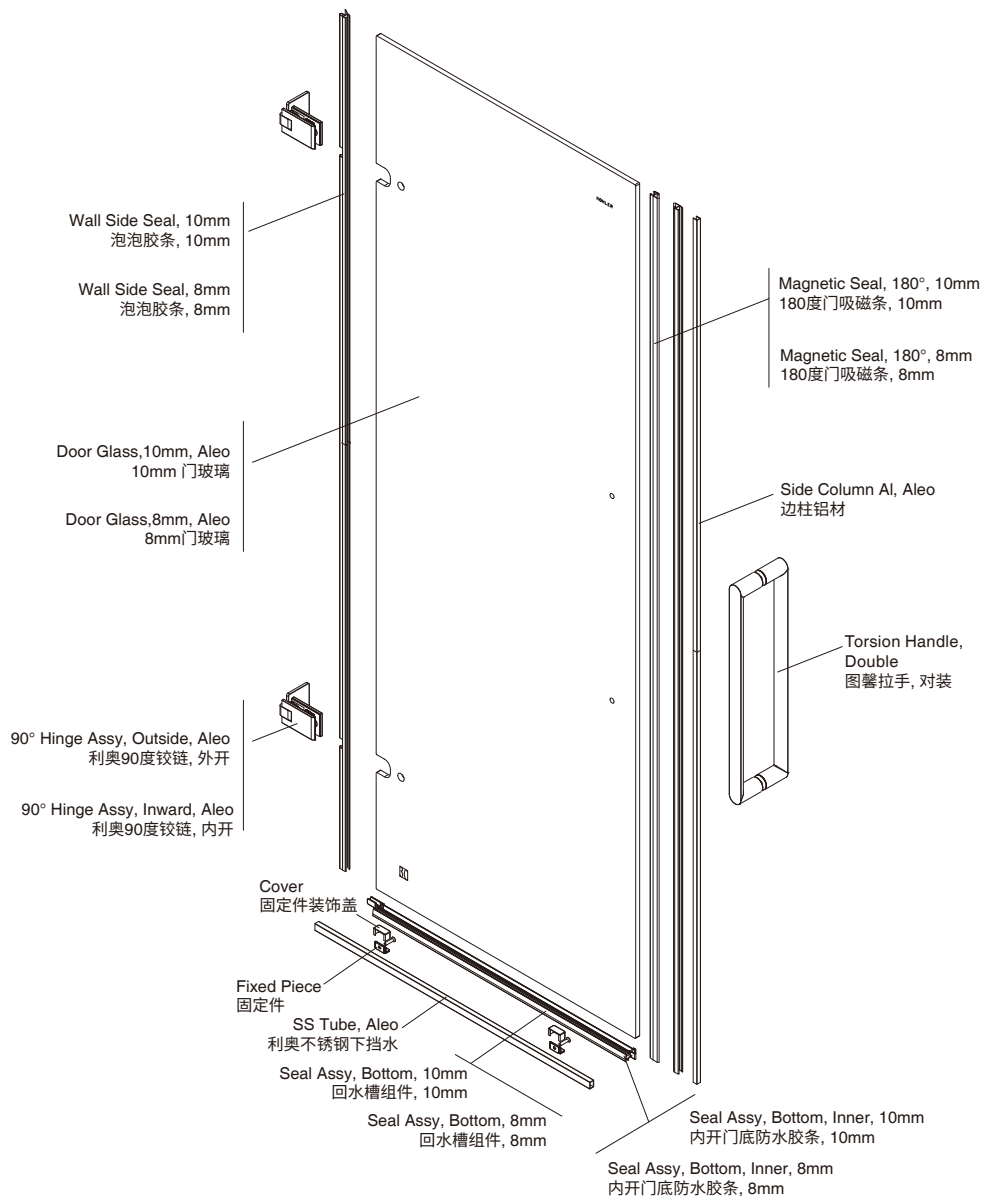

	x2	90° Hinge Assy, Aleo 利奥90度铰链
	x1	Side Column Al, Aleo 边柱铝材
	x1	Torsion Handle, Double 图馨拉手,对装
	x2	Cover 固定件装饰盖
	x2	Fixed Piece 固定件
	x1	SS Tube Assy, Aleo 利奥不锈钢下挡水组件

	x1	Seal Assy, Bottom 回水槽组件
	x1	Wall Side Seal 泡泡胶条
	x1	Magnetic Seal 180度门吸磁条
	x6	Pan Screw ST3.5x40, 圆头螺丝ST3.5x40
	x6	Hollow Wall Anchor, Nylon 膨胀套

Tools Required/所需工具

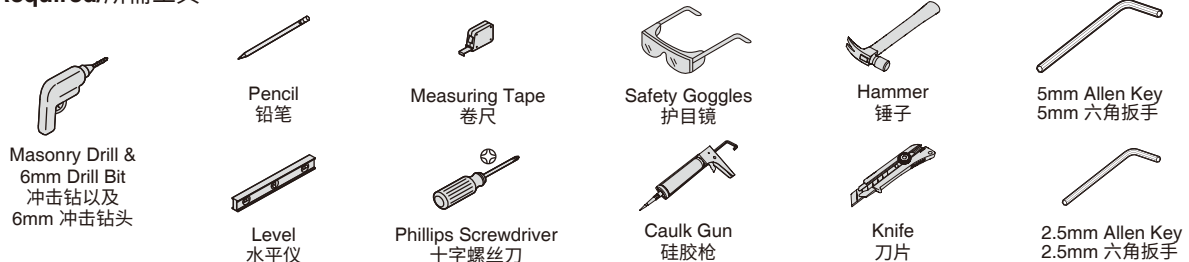

Install the tube so that it is horizontal.
放置挡水条, 需确保挡水条放置水平。

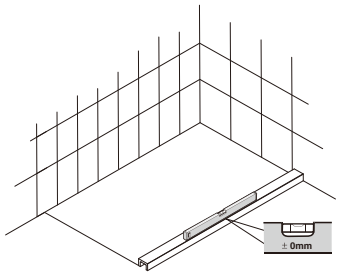

IMPORTANT:
Tray **MUST** be level along front edge.
重要:
底盘必须水平。

STEP 1

Install accessories onto the door glass:

- 安装门玻上面的配件:
1. Install the wall hinge
1、安装上墙铰链;
2. Install the wall side seal
2、安装侧边泡泡胶条;

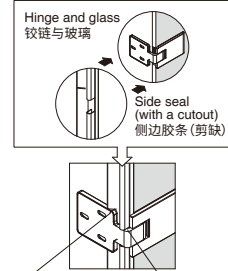

Note: The soft side shall be flattened against the end cover.
注意: 软边撕口贴平端盖安装。

Note: The cutout in the side seal shall be flush against the end surface of the turn on the hinge.
注意: 侧边胶条上缺口贴合铰链弯臂端面安装。

STEP 2

Install the door glass: Draw lines and drill holes. Insert the hollow wall anchor. The vertical side shall be 24mm from the lower edge of the tube and the door glass shall be 30mm from the external edge.
安装门玻: 划线, 钻孔, 套入胶粒, 门玻垂直方向距离挡水边高度为24mm, 门玻内偏30mm安装。

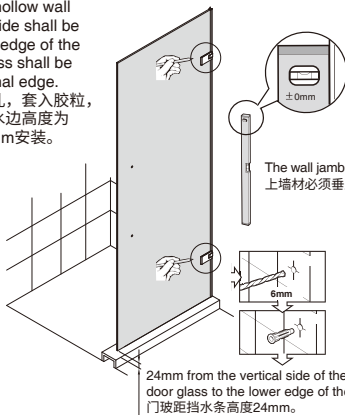

The wall jamb **must** be kept vertical.
上墙材必须垂直。

24mm from the vertical side of the door glass to the lower edge of the tube.
门玻距挡水条高度24mm。

STEP 3

Install the wall channel 20mm away from the glass.
安装上墙铝材, 上墙材到玻璃距离为20mm左右。

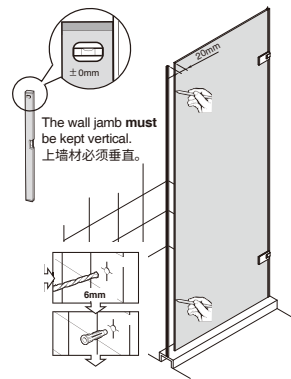

The wall jamb **must** be kept vertical.
上墙材必须垂直。

STEP 4

Install the bottom waterproof structure. (Note: This structure shall be parallel to the tube)
安装下挡水材, (注意: 安装时请注意与挡水边平行)

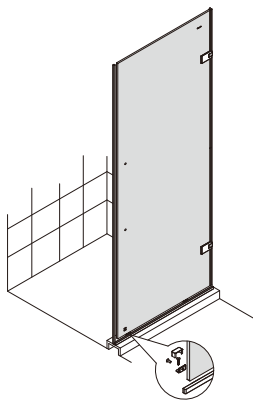

STEP 5

Install the bottom waterproof seal and the magnetic strip.
安装下挡水胶条和磁条。
Note: Cut the bottom waterproof seal where the gutter passes through so that the door can be closed.
注意: 下挡水胶条需剪去引水槽, 不干涉关门即可

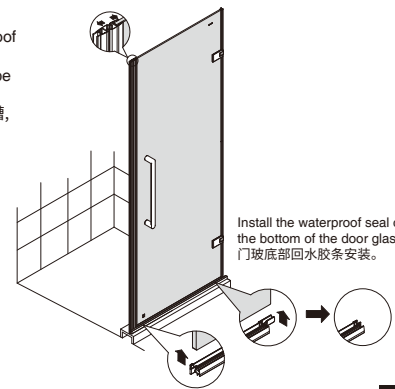

Install the waterproof seal on the bottom of the door glass.
门玻底部回水胶条安装。

STEP 6

Apply the silicone sealant.
打防水胶。

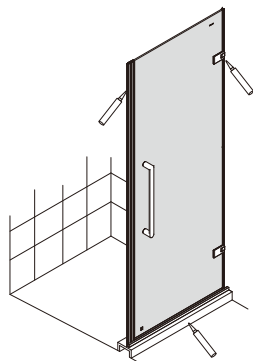

STEP 7